



LYSAGHT TOPSPAN 22 / 40

Steel roof and ceiling battens for non cyclonic applications

Our TOPSPAN® 22 ceiling batten and TOPSPAN 40 roof battens are the economical alternative to timber battens.

TOPSPAN battens are quicker and easier to install because they can be lapped, thus eliminating the time-consuming process of cutting to length. Consistent straightness simplifies alignment, and fastening is quick and easy using self-drilling screws.

Batten ends are mitre-cut for simple installation at hip and valleys.

There's a TOPSPAN product that's right for your building application.



Structural Solutions



Rainwater Solutions



Roofing & Walling Solutions



Fencing Solutions



Home Improvements



House Framing Solutions



Customer Support



TOPSPAN 22 ceiling batten

Material specifications

TOPSPAN 22 ceiling battens are made from ZINCALUME® steel (aluminium/zinc alloy coated) complying with AS1397 G550, AZ150

(550 MPa minimum yield stress, 150 g/m² minimum coating mass).

Thickness (BMT) (mm) 0.42

Yield Strength (MPa) 550

Coating Mass (g/m²) 150

Masses (kg/m) 0.36

Total coated thickness (mm) 0.47

Standard Length (mm) 6100

Tolerances

Length (mm) ± 5

Web (mm) + 1 - 0

Flange (mm) + 1 - 0

Light, strong, economical

TOPSPAN® 22 steel ceiling battens are versatile and easy to use, providing strength, lightness and rigidity with low cost. TOPSPAN ceiling battens are compatible with all popular domestic ceiling boards.

Many plaster board fixers now use TOPSPAN 22 ceiling battens to resist plasterboard cracking due to timber movement. They also prevent 'nail popping' caused by shrinkage. They are also useful in a range of other applications where strength, rigidity and straightness are requirements.

TOPSPAN 22 is produced in ZINCALUME® steel for longer life.

Capacity

For supporting 13 mm plasterboard:

Maximum span of batten 1200 mm

Max. spacing of batten 600 mm

Packing

Sections are normally supplied in strapped bundles of 50. Packing for non-standard lengths will be determined by length and mass considerations. Other forms of packing subject to enquiry.

Handling & storage

Steel ceiling battens must be kept dry in transit and stored clear of the ground under cover to prevent water and/or condensation being trapped between adjacent surfaces. If packs become wet, sections should be separated, wiped with a dry cloth without delay and placed so that air circulation completes the drying process.

TOPSPAN 22

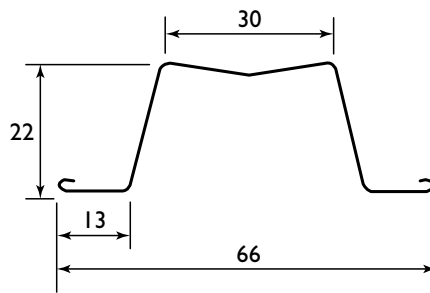

These procedures are recommended to avoid possible deterioration of the coating which could lead to a reduced life expectancy.

For further information contact Steel direct on 1800 641 417.

Caution

Do not walk on battens between joists.



Installation options

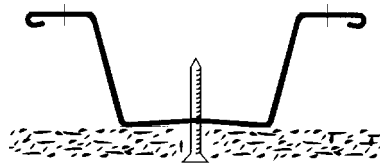

Plasterboard to batten

Use No.8 x 25 mm self-drilling S-point gypsum (dry wall) screws.

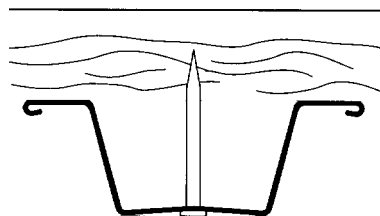

Batten to timber joists

Fasten through the crest at every support using one 2.5 mm dia. x 60 mm galvanised clout.

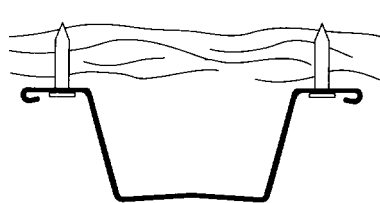

Batten to timber joists

Use one 2.5 mm dia. x 30 mm galvanised clout or one No. 10 x 20 mm screw through each flange at each support.

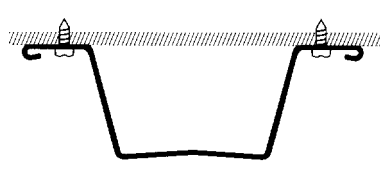

Batten to steel joists or truss chords

Fasten at each support using two No. 10 x 12 mm pan head self-drilling screws, one through each flange.

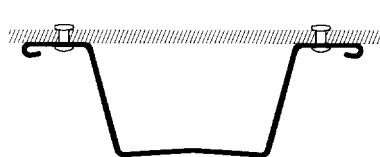

Batten to steel joists or truss chords

Use one 3.2 diameter blind rivet through each flange at each support. (Rivet length to rivet manufacturer's specification.)

TOPSPAN 40 roofing batten

Our TOPSPAN® 40 roof battens are the economical alternative to timber roof battens. Made from high-tensile Australian steel, TOPSPAN 40 roof battens are lighter than timber battens. Storage, carrying and handling are easier, because they nest together. TOPSPAN 40 battens are quicker and easier to install because they can be lapped, thus eliminating the time-consuming process of cutting to length. Consistent straightness simplifies alignment, and fastening is quick and easy using self-drilling screws.

Batten ends are mitre-cut for simple installation at hip and valleys. And the rolled edges on TOPSPAN 40 battens add safety when handling.

Material specifications

TOPSPAN 40 battens are made from ZINCALUME® steel (aluminium/zinc alloy coated) complying with AS1397 G550 — AZ150 (550 MPa minimum yield stress, 150 g/m² minimum coating mass).

Thicknesses (BMT) (mm)	0.55
Yield Strength (MPa)	550
Coating Mass (g/m ²)	150
Mass (kg/m)	0.62

TOPSPAN 40

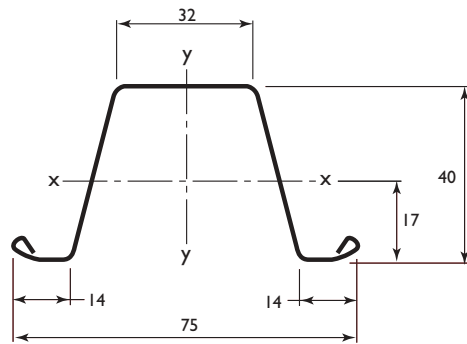

Installation options

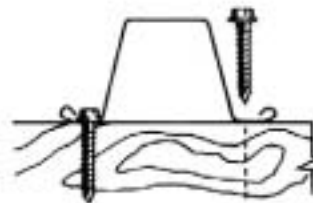

Fastening batten to timber

(See note 3 on the following page for fastener selection on sheet roof.)

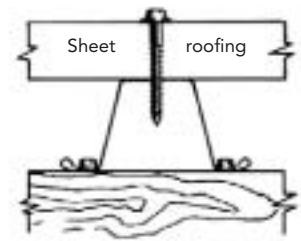

Sheet roofing

Type 17 Hex. washer head self-drilling screw. See roofing data sheets for screw details, fastener frequency, etc.

Ridge detail - sheet roofing

Fix through flashing into battens using specified screws.

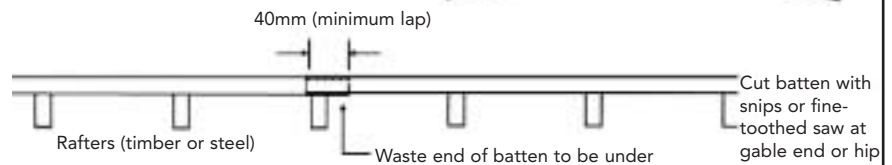
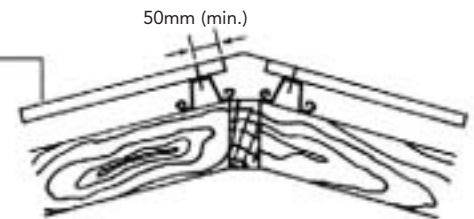

Lapping battens

To minimise cutting, lay all battens in one direction, starting from one end of roof. Hip-valley roofs: lay battens starting from valley.

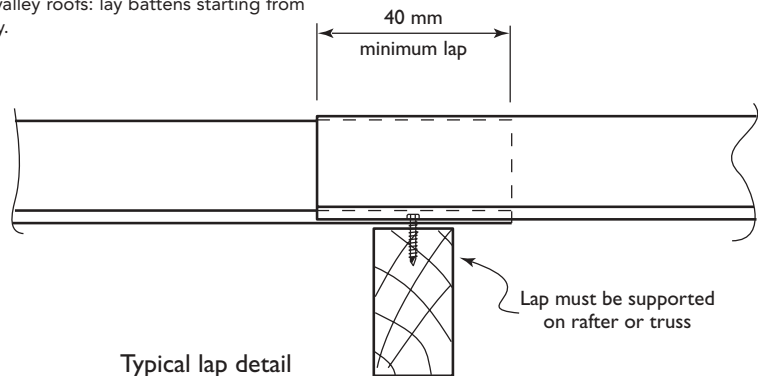

Allowable batten spacing in Non cyclonic areas

- The tables are based on a general design approach. The tables will give a practical and economic solution for most domestic buildings in non-cyclonic areas. For specific design situations, information on fastener and batten capacity may be obtained from BlueScope Lysaght's Steel Direct (all relevant details should be forwarded to your nearest BlueScope Lysaght office).
- The design pressures have been determined from AS 1170.2, 1989, Section 3, for buildings up to 6 metres high with pressure coefficients of +0.2 internally and -0.9 externally with a local pressure factor of 1.5.
- Fastener selection for sheet roof:
 - For pine 2 off 12 - 11 x 40 Type 17 per joint
 - For wind categories W28, W33, W41 - minimum Truss chord material 1.0 BMT- 2 off 10 - 16 x 16*
 - W50 & W60 - minimum Truss chord material 1.2 BMT - 2 off 12 - 14 x 20*
 - W70 - minimum Truss chord material 1.6 BMT - 2 off 12- 14 x 20*
- Fastener selection for tile roof: 1 off 10 - 16 x 16 Hex. self-drilling screws per joint alternating top and bottom. Use 2 per joint at free ends.

TOPSPAN 40 Battens

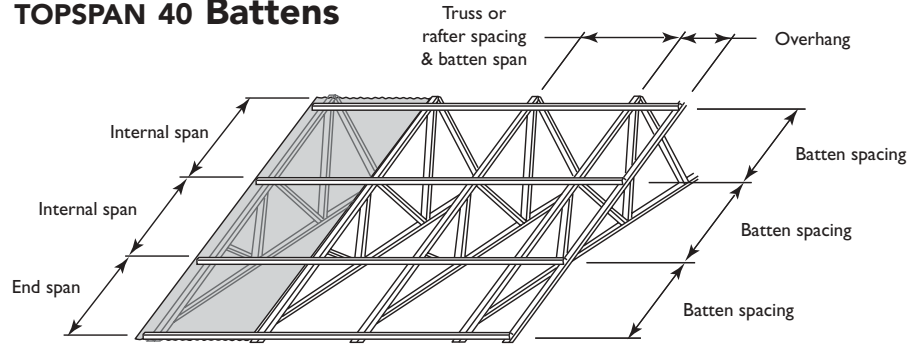

- Fastener selection for cladding: 12 gauge Type 17 or 12 - 11 reduced drill point as per standard BlueScope Lysaght recommendations.
- Maximum batten span is 1200 mm for sheet or tile roof.
- Roof truss design may be based on a maximum batten spacing. The designer/fabricator should be contacted for this information. BlueScope Lysaght truss designs have 1200mm maximum batten spacing.
- Batten overhang should not exceed 300 mm without engineering approval.
- The tables have been determined based on the following assumptions:
 - Batten is over three continuous spans
 - All trusses/rafters are uniformly spaced.
 - Fastener pullout loads determined for batten to Z chord connection.
- For sheet roof applications, batten connections to the chord of the first truss in from the gable end should be strapped if the batten spacing is less than 1400mm and the truss spacing is 450mm. Strapping shall be 1.0 x 25mm fastened to the web of the truss chord with 2 off 10 - 16 x 16 Hex. self-drilling screws.

Allowable batten spacing (non-cyclonic)

ROOF CLADDING	BMT	Span type	Design wind speed W28N1			Design wind speed W33N2			Design wind speed W41N3		
			Truss spacing (mm)			Truss spacing (mm)			Truss spacing (mm)		
			600	900	1200	600	900	1200	600	900	1200
CUSTOM ORB	0.42	End	900	900	900	900	900	900	900	900	900
		Internal	1200	1200	1200	1200	1200	1200	1200	1200	1000
	0.48	End	1200*	1200*	1200*	1200*	1200*	1200*	1200*	1200*	1000*
		Internal	1600*	1600*	1600*	1600*	1600*	1540*	1600*	1330*	1000*
CUSTOM BLUE ORB	0.60	End	900	900	900	900	900	900	900	900	900
		Internal	1200	1200	1200	1200	1200	1200	1200	1200	1000
	0.80	End	1800*	1800*	1800*	1800*	1800*	1540*	1800*	1330*	1000*
		Internal	2400*	2400*	2150*	2400*	2060*	1540*	2000*	1330*	1000*
TRIMDEK	0.42	End	1000	1000	1000	1000	1000	1000	1000	1000	1000
		Internal	1700	1700	1700	1700	1700	1540	1700	1330	1000
	0.48	End	1700	1700	1700	1700	1700	1540	1675	1330	1000
		Internal	2300	2300	2150	2300	2060	1540	2000	1330	1000
SPANDEK	0.42	End	1500	1500	1500	1500	1500	1500	1500	1330	1000
		Internal	2100	2100	2100	2100	2060	1540	2000	1330	1000
	0.48	End	1950	1950	1950	1950	1950	1540	1940#	1330	1000
		Internal	2800	2800	2150	2800	2060	1540	2000	1330	1000
KLIP-LOK	0.42	End	1200	1200	1200	1200	1200	1200	1200	1200	1000
		Internal	1300	1300	1300	1300	1300	1300	1300	1300	1000
	0.48	End	1800	1800	1800	1800	1800	1540	1800	1330	1000
		Internal	2100	2100	2100	2100	2060	1540	2000	1330	1000
	0.60	End	2300	2300	2150	2300	2060	1540	2000	1330	1000
		Internal	2700	2700	2150	2700	2060	1540	2000	1330	1000
KLIP-LOK 700	0.42	End	1100	1100	1100	1100	1100	1100	N/R	N/R	N/R
		Internal	1300	1300	1300	1300	1300	1300	N/R	N/R	N/R
	0.48	End	1800	1800	1800	1800	1800	1540	1800	1330	1000
		Internal	2100	2100	2100	2100	2060	1540	2000	1330	1000

ROOF CLADDING	BMT	Span type	Design wind speed W50			Design wind speed W60			Design wind speed W70		
			Truss spacing (mm)			Truss spacing (mm)			Truss spacing (mm)		
			450	600	900	450	600	900	450	600	900
CUSTOM ORB	0.42	End	900	900	900*	870*	870*	790*	645*	645*	645*
		Internal	1200	1200	1140*	1095*	1095*	790*	810*	810*	710*
	0.48	End	1200*	1200*	1140*	1165*	1165*	790*	1000*	1000*	710*
		Internal	1600*	1600*	1140*	1580*	1180*	790*	1310*	1150*	710*
CUSTOM BLUE ORB	0.60	End	900*	900*	900*	870*	870*	790*	645*	645*	645*
		Internal	1200*	1200*	1140*	1095*	1095*	790*	810*	810*	710*
	0.80	End	1460*	1460*	1140*	1275*	1180*	790*	1045*	1045*	710*
		Internal	1885*	1700*	1140*	1580*	1180*	790*	1285*	1150*	710*
TRIMDEK	0.42	End	1000	1000	1000	N/R	N/R	N/R	N/R	N/R	N/R
		Internal	1435	1435	1140	N/R	N/R	N/R	N/R	N/R	N/R
	0.48	End	1405	1405	1140	1225	1180	790	1075	1075	710
		Internal	2050	1700	1140	1580	1180	790	1460	1150	710
SPANDEK	0.42	End	1500#	1500#	1140#	1125#	1125#	790#	N/R	N/R	N/R
		Internal	1975#	1700#	1140#	1365#	1180#	790#	N/R	N/R	N/R
	0.48	End	1655#	1655#	1140#	1265#	1180#	790#	935#	935#	710#
		Internal	2230#	1700#	1140#	1575#	1180#	790#	1165#	1150#	710#
KLIP-LOK	0.42	End	1145	1145	1140	N/R	N/R	N/R	N/R	N/R	N/R
		Internal	1300	1300	1140	N/R	N/R	N/R	N/R	N/R	N/R
	0.48	End	1350	1350	1140	1015	1015	790	N/R	N/R	N/R
		Internal	1635	1635	1140	1250	1180	790	N/R	N/R	N/R
	0.60	End	1605	1605	1140	1350	1180	790	1120	1120	710
		Internal	2080	1700	1140	1580	1180	790	1330	1150	710
KLIP-LOK 700	End or internal	Not recommended									

Key: * 5 fasteners per sheet # 4 fasteners per sheet N/R Not recommended.



Non-cyclonic areas

The information in this brochure is suitable for use only in areas where a tropical cyclone is unlikely to occur as defined in AS 1170.2—1989 *SAA Loading Code, Part 2: Wind Loads*.

Ask for advice from our information service on designs to be used in cyclonic areas.

LYSAGHT TOPSPAN

Design Advantages

- Economical, lightweight alternative to timber battens or light gauge purlins and girts (depending on size and thicknesses)
- Made from high tensile Australian steel
- Fast and easy to install because they can be lapped
- Consistent straightness simplifies alignment
- Fastening is quick and easy with self drilling screws
- Can be used in many commercial and domestic applications including sheds, garages and carports
- Easily stacked, stored and transported
- A versatile solution for uses as battens for ceilings or roofs, or as light steel sections



For information, brochures
and your local distributor call

1800 641 417

Please check the latest
information which is
always available at
www.lysaght.com

© Copyright BlueScope Steel Limited 22 September 2003

LYSAGHT®, TOPSPAN®, ZINCALUME® and GALVABOND®
are trademarks of BlueScope Steel Limited
A.B.N. 16 000 011 058

The LYSAGHT® range of products is exclusively made by
BlueScope Steel Limited trading as BlueScope Lysaght.



9 320075 034962